

# ScanINSPECT VPI™

"Virtual Product Inspection"



## WHAT IS ScanINSPECT VPI?

ScanINSPECT VPI is a fully integrated, stand-alone process control, measurement, inspection and programming workstation for use in setting up processes before the production floor or performing sampling inspection once a product is in production in the PCB or Hybrid Microcircuit assembly industries.

ScanINSPECT VPI uses a PC Windows based software package integrated with a high-resolution, calibrated, A3 size flatbed scanner. This combination allows inspection of artwork, PCB's, ceramic substrates, components, stencils and screens at virtually any stage of the production process. Parts can be inspected versus either Gerber data, CAD data or golden parts. All variables come together as a virtual part to avoid costly problems before full production starts.

## PCB ASSEMBLY APPLICATIONS

ScanINSPECT VPI is capable of performing many different functions in a PCB Assembly facility such as:

- Design – Check Holes, Slots, Real Estate.
- Components – Compare parts from Multi-vendors including shape, color, size.
- Bare Boards – FR4, Ceramic or Flex parts. Compare from multi-vendors. Compare to Gerber or to the stencil.
- Stencils/Screens – Detect stretch, wear, missing, blocked or damages apertures. Use for incoming inspection or in production after cleaning.
- Wet Boards – Compare paste or adhesive to Gerber, stencil or golden part.
- Loaded Boards – Compare component locations, rotation, package type, etc to CAD data. First Article Inspection!

**All variables come together in a virtual system before production!**

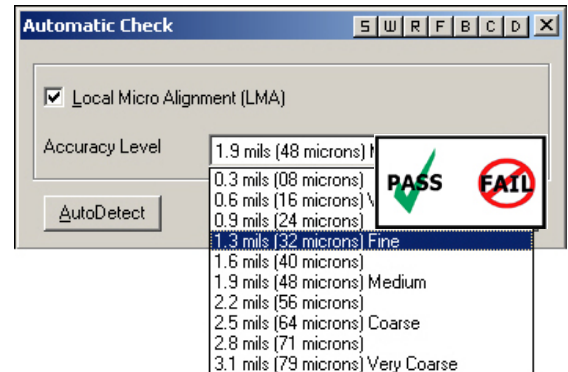

## PROGRAMMING SYSTEM

In addition to inspecting a virtual part to avoid costly production problems, the ScanINSPECT VPI system can also be used for programming.

- Create through hole or SMT assembly programs from either Gerber data, ASCII centroid data or scanned images of PCB's, film, stencils, etc.
- Create component vision files for SMT placement equipment from scanned images of components. Off-line programming and no more calipers!!

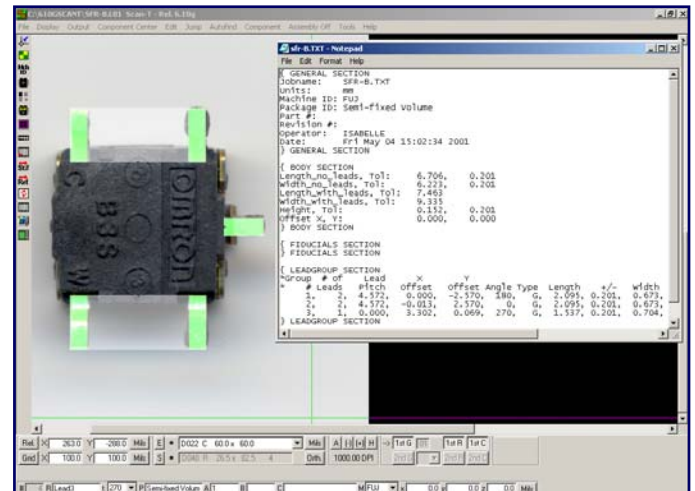

## SIMPLE OPERATION

The ScanINSPECT VPI system can be quickly learned and is simple to operate. Most inspection operations only take a few steps and can be completed very quickly. Operators can step between defects and zoom in and out to verify errors. Inspection reports can be easily generated.

## REVERSE ENGINEERING

The optional FabScan software module can easily be added to ScanINSPECT VPI providing even more powerful capability to the system. Create the Gerber data and drill files necessary to manufacture a PCB when CAD data does not exist.

FabScan adds the capability of scanning PCB's, stencils, film, drawings or even hand taped designs and producing the Gerber data and Drill files necessary to manufacture the PCB.

It also contains a full Gerber editor that can be used to modify the Gerber data as necessary. The Fabscan product contains many powerful automatic software functions to quickly and easily vectorize pads, tracks, ground planes, silkscreen, etc.

Worried about the quality of the finished Gerber files? Use FabScan's "check functions" to verify the accuracy of the data. The resulting Gerber X data files set the quality standard in the industry

## PROCESS SETUP & PROCESS CONTROL

As shown in the following several examples, ScanINSPECT VPI has the ability to store images of all assembly process steps and the Gerber/CAD in different layers to easily find issues before full production starts or while sampling during production. Multiple Gerber layers can also be used such as PCB Gerber, Stencil Cut Gerber, etc.

Perform the following inspection functions:

- PCB vs. Gerber data
- Stencil vs. Gerber data
- Stencil vs. Stencil or PCB to PCB – Compare parts from different vendors
- Stencil vs. PCB
- Populated PCB vs. CAD data – First Article Inspection
- Wet materials such as Solder or Adhesive vs. Gerber or Stencil.
- Artwork or Film vs. Gerber, Stencil or PCB
- Similar Components from different vendors
- Others

## ELIMINATE SURPRISES!

Use ScanINSPECT VPI to catch problems **BEFORE** the production floor and eliminate surprise..!

By catching PCB or Hybrid Microcircuit problems before production (virtual problems), costly rework is dramatically reduced (real problems).

In addition, create assembly programs and component vision files and with the optional FabScan software module, create Gerber and/or drill files from scanned images of PCB's, film, stencils, etc. All on one low-cost, easy to use system!



## COMPARE PCB TO GERBER

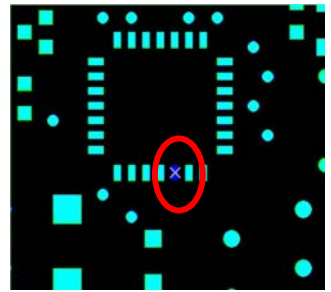
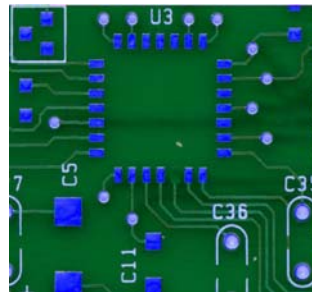
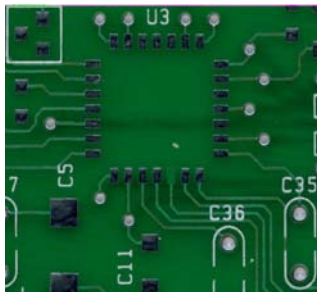
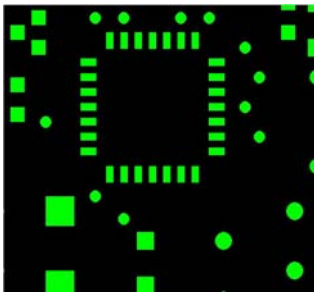

Input Gerber



Scan PCB in  
Color



Convert to  
Raster



Overlay and  
Automatic  
Inspection

## COMPARE STENCIL TO GERBER

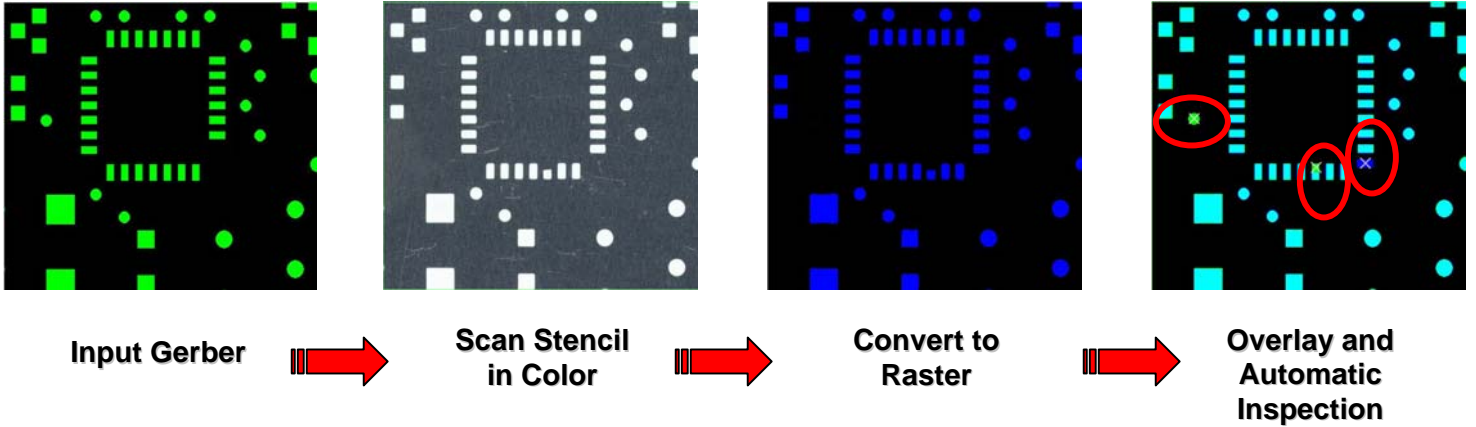

## COMPARE PCB TO STENCIL

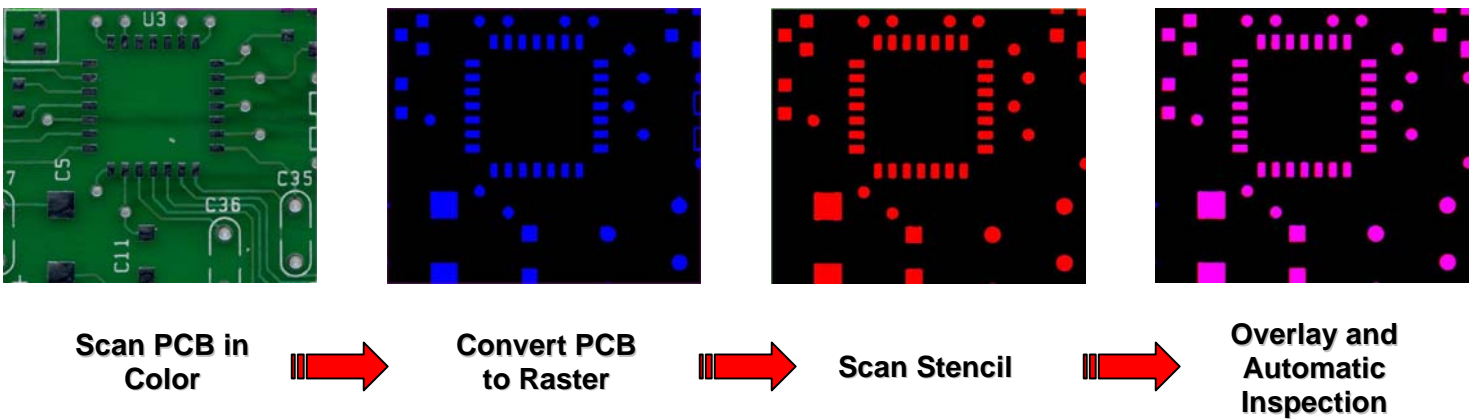

## FIRST ARTICLE COMPONENT PLACEMENT INSPECTION

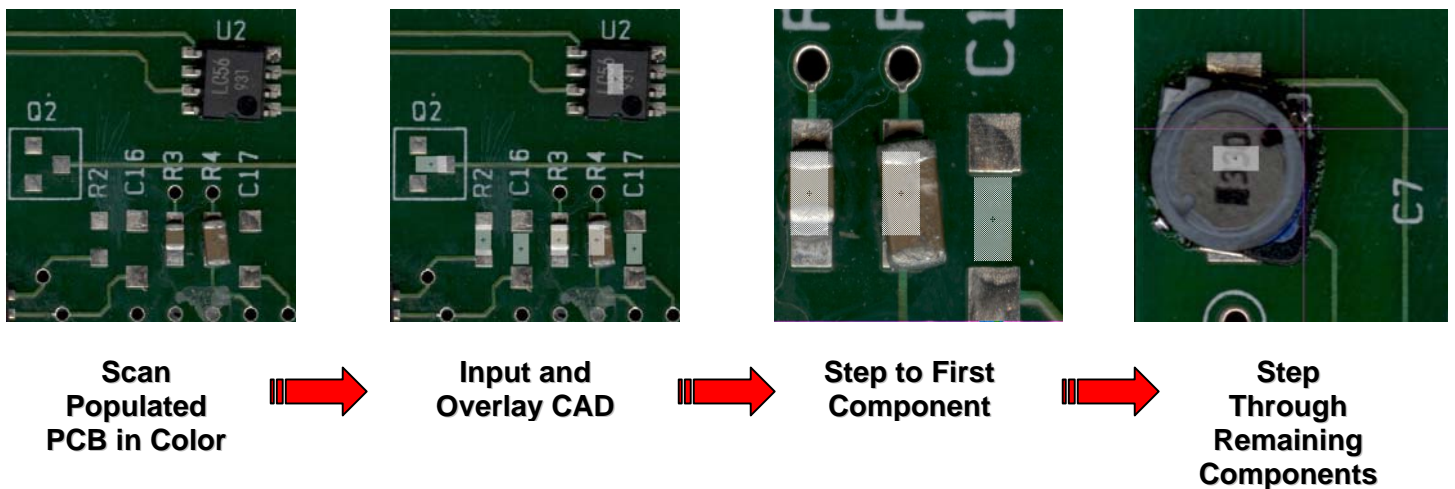

## SYSTEM FEATURES

### WORKSTATION DESK SYSTEM

- Contact System
- Scanner Faces Up
- Part Faces Down
- Dry Parts or Wet Parts with Standoffs
- Large Part Capability with Multiple Scans

### SCANNING

- B&W or Color Imaging
- Top or Bottom Lighting
- Glass Plate Calibration
- Automatic Raster to Gerber Alignment

### MEASUREMENT AND INSPECTION FUNCTIONS

- Verify feature sizes to 0.0005" and feature absence/presence as small as 0.002" (0.050mm)
- User Defined or Automatic Inspection Accuracy Level Setting.
- Check Feature Size, Shape and Position.
- Check Gerber Image against Scanned Image
- Compare Gerber Image against Gerber Image
- Check Scanned Image against Scanned Image
- Overlay ASCII Centroid Data over Scanned Image
- Point to Point Measurement Functions
- Perform Area Inspection Function of Scanned Features Such as Apertures, Pads, Wet Material, etc.

### PROGRAMMING FUNCTIONS

- ASCII CAD, Gerber and BOM Inputs
- Scanned Images of PBS's, Film, Drawings, Stencils, Components, etc
- Create Assembly Programs From Gerber or Scanned Images When No CAD or Gerber Available
- Create Component Vision Files from Scanned Images of Components

### OUTPUTS

- Pass/Fail Inspection Report
- Rework File Generation
- Over 70 Different Machine Output Formats
- Many CAM Package Outputs Supported
- Direct Component Vision File Generation for Fuji SMD3 and Siemens SIPLACE Pro
- Generic Component Vision File for Other Placement Machine Suppliers
- Gerber Files (274D & 274X)
- Comprehensive Aperture Tables
- Stencil Files
- HP-GL, DXF, PCX and TIFF Files

## TECHNICAL SPECIFICATIONS

### SCANNER

- High-Resolution Color Flatbed Scanner, Size A3: (400/1000/2000/3200\*/4800\* dpi)
- Calibrated Accuracy:  $\pm 0.0015"$  ( $\pm 0.0381\text{mm}$ )
- A3-Scanning Bed Area: 11.7" x 16.5" (297mm x 419mm)
- Maximum Work Area: 32.0" x 32.0" (813mm x 813mm)

\*Reduced scanning area for 3200 & 4800 dpi

### COMPUTER\*

- Pentium (3GHz) Personal Computer
- 80 GB HD, 2 GB RAM
- CD-ROM (CD-RW for archive purposes)
- Monitor (17" or larger)
- Printer
- Windows XP – Requires:  
2 available USB ports

\*Recommended customer supplied minimum PC requirements.

### ADDITIONAL SYSTEM COMPONENTS

- Precision Glass Calibration Grid
- ConvertPLUS CAM Software
- Software Protection Key
- Custom Transmissive Lighting Package
- Custom Workstation Desk
- Scanning Accessory Package



The following are trademarks of the indicated companies: Gerber, The Gerber Scientific Instrument Company; HP-GL, HP, Hewlett-Packard; Windows XP, Microsoft®.

(All specifications and designs subject to change without notice.)



PO Box 598, 19181 Hwy 8  
Morrison CO 80465-0598 USA  
T: 303.697.8888 F: 303.697.8580  
E: [info@scancad.com](mailto:info@scancad.com) [www.scancad.com](http://www.scancad.com)